

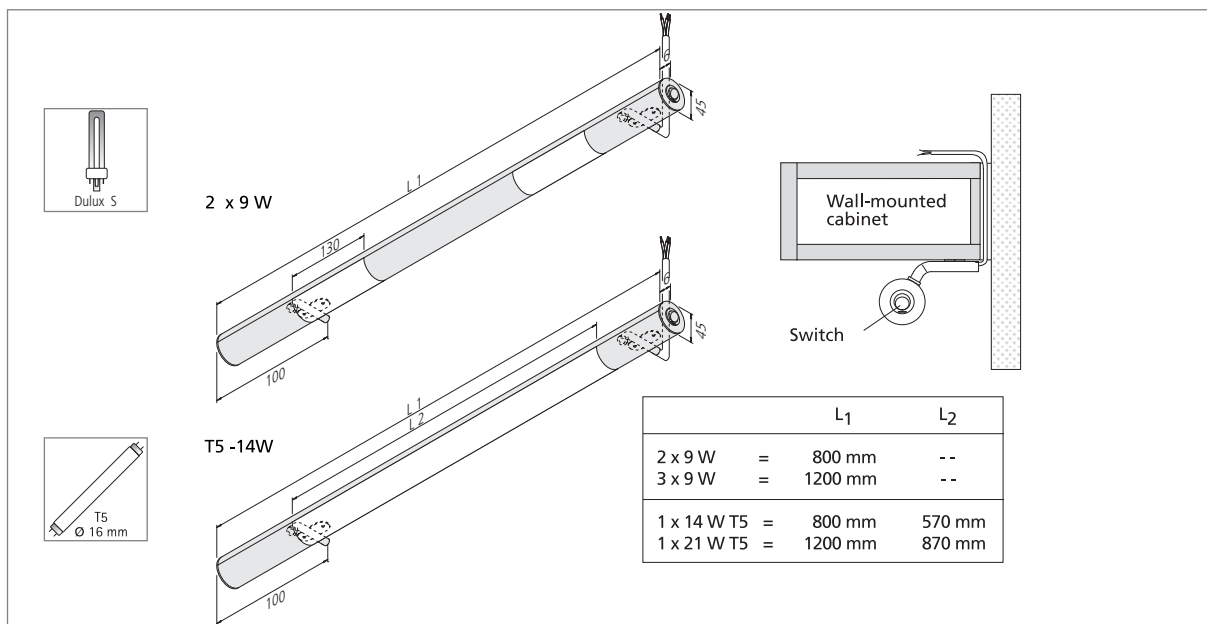

Fluorescent Under-Cabinet Luminaire with Switch

- Application:** upmarket lighting solution for the smallest of spaces in kitchens and shops
- Connection:** T5: 220 – 240V / 50 – 60Hz // DULUX S: 230V / 50Hz
- Lamp:** extremely long-life T5 (ø 16mm) high efficiency fluorescent lamp, ø life 20,000 hours / or compact fluorescent lamp DULUX S, ø life 8,000 hours
- Energy efficiency:** good – very good, 67 – 90lm/W (9 – 21W)
- Colour rendering:** good, Ra = 80 – 89
- Special features:** built-in side switch; with compact fluorescent lamp or T5 lamp; available in two lengths with different light outflows.



Article No.	Description	Features	Approx. weight
501 320 106 01	Boston 800mm 2x9W Dulux	<ul style="list-style-type: none"> • anodised aluminium/colour appearance cw (cool white) • mains cable 2m with shockproof plug D/F/B supplied loose 	1230 g
501 320 206 01	Boston 1200mm 3x9W Dulux	<ul style="list-style-type: none"> • Safety rating 1 	1920 g
501 320 106 11	Boston 800mm 1x14W T5	<ul style="list-style-type: none"> • anodised aluminium/colour appearance cw (cool white) • mains cable 1.6m with shockproof plug D/F/B supplied loose 	940 g
501 320 206 11	Boston 1200mm 1x21W T5	<ul style="list-style-type: none"> • Safety rating 2 	1400 g