

GDS 1-LED



LED
Fluorescent



LED Glass Shelf Light

- Application:** Accent lighting for kitchens and shops
- Connection:** 220 - 240V / 50 - 60Hz
- Lamp:** extremely long-life 70mW LED, ϕ life 30,000 hours
- Energy efficiency:** good, ww: 55lm/W; cw: 65lm/W
- Colour rendering:** good, ww: Ra = 90; cw: Ra = 85
- Special features:** no UV-rays; 8mm tempered safety glass for loads up to 10kg; easy to adjust with knurled screws; version with switch on request.

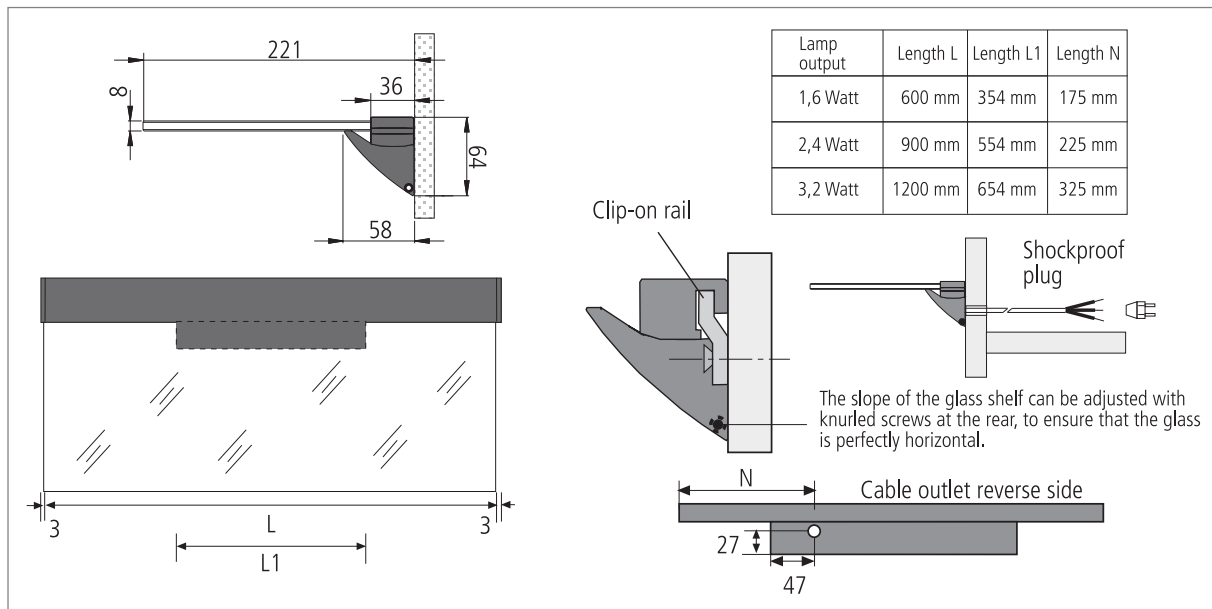

Article No.	Description	Features	Approx. weight
610 011 811 01	GDS 1-LED 600mm 1,6W ww	<ul style="list-style-type: none"> light colour ww (warm white) stainless steel look mains cable 2m with shockproof plug D/F/B supplied loose 	3300 g
610 011 812 01	GDS 1-LED 900mm 2,4W ww	<ul style="list-style-type: none"> light colour ww (warm white) stainless steel look mains cable 2m with shockproof plug D/F/B supplied loose 	5100 g
610 011 813 01	GDS 1-LED 1200mm 3,2W ww	<ul style="list-style-type: none"> light colour ww (warm white) stainless steel look mains cable 2m with shockproof plug D/F/B supplied loose 	6500 g
610 011 801 01	GDS 1-LED 600mm 1,6W cw	<ul style="list-style-type: none"> light colour cw (cool white) stainless steel look mains cable 2m with shockproof plug D/F/B supplied loose 	3300 g
610 011 802 01	GDS 1-LED 900mm 2,4W cw	<ul style="list-style-type: none"> light colour cw (cool white) stainless steel look mains cable 2m with shockproof plug D/F/B supplied loose 	5100 g
610 011 803 01	GDS 1-LED 1200mm 3,2W cw	<ul style="list-style-type: none"> light colour cw (cool white) stainless steel look mains cable 2m with shockproof plug D/F/B supplied loose 	6500 g