

# LED – The future of energy efficient lighting



***Hera***<sup>®</sup>  
Light Years Ahead.



The light-emitting diode (LED) is not only one of the most energy-efficient lamps available today, it also adds a personal touch to lighting design.

The LED is a semiconductor crystal that emits visible light when charged with electricity. A crystal measuring just a few millimetres is positioned on a reflector which conducts the light with total accuracy. The reflector and crystal are affixed to a bracket containing the electrical contacts. The bracket with the crystal and reflector is typically encapsulated in epoxy resin.

The colour of the LED light depends on the composition of the crystal. For instance, white light is generated by converting a blue diode with a fluorescent layer.

## Types of LED



The T-type LED is the original style. Because the sealed casing does not allow heat to dissipate, this style is not suitable for high luminous power applications, but only as a signal/readiness indicator.



With the SMD „Surface Mounted Device“ style, the component is adhered directly to the printed circuit board. The output ranges differ considerably here. On many LEDs with a small single-power source, series resistors can be accommodated in the luminaire, and connected in parallel to constant-voltage LED transformers (similar to halogen luminaires).



With the SMD type of individual high-output LEDs (here an example of a luminaire with an energy efficiency of approx. 50 lm/W developed in 2003), the luminaires should be connected in series to constant-current LED transformers (unused sockets must be provided with short-circuit plugs).

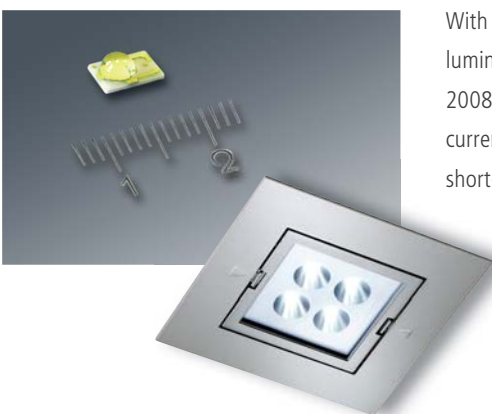

With the new high power SMD-style LEDs (here an example of a luminaire with an energy efficiency of 80 - 100 lm/W developed in 2008) the luminaires should also be connected in series to constant-current LED transformers (unused sockets must be provided with short-circuit plugs).

## Energy efficiency

The efficiency of LEDs is constantly improving. Currently the best power-LEDs have an efficiency of 120 lm/W. We expect the light output of white LEDs to increase even more over the next few years, making them more attractive for general lighting purposes. The LED range extends from small signal/readiness indicators to the latest high-power LEDs.

### Comparison of energy efficiency

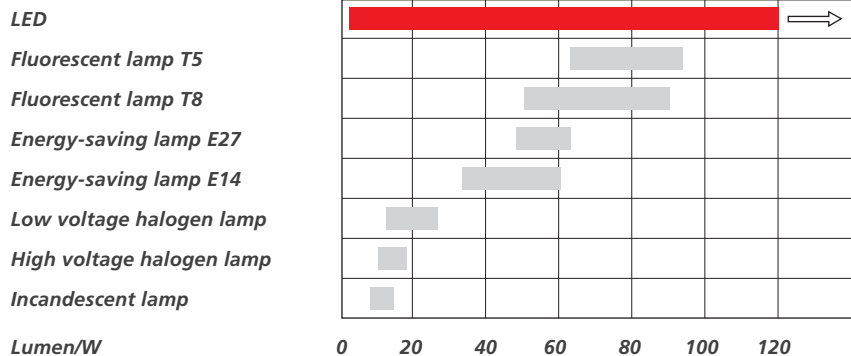

## Deterioration and service life

The luminous intensity of a luminescence diode steadily decreases when operated under constant conditions. The average LED has a very long service life. As it reaches the end of its life, it does not suddenly fail, but gradually fades to 70% or 50% (depending on manufacturer) of its original brilliance. Subjecting an LED to high currents and high ambient temperatures substantially reduces its life. Total failures are very rare, and these usually occur as a result of overloading or incorrect connection.

With LEDs used only for signal purposes, e.g. as a TV standby indicator, a service life of over 100,000 hours (11½ years of uninterrupted light) can be expected. Intermittently switching off an LED allows it to rejuvenate itself, extending its service life. Today it is already one of the most cost-effective lamps available, because

servicing and lamp replacement are unnecessary. To a large extent the life of a luminaire depends on its design, which should keep the LED chip cool by dissipating the heat efficiently.

In other words, the design of a luminaire, especially the provision of heat sinks, plays an important role in determining the life expectancy of the LEDs.

### Service life of different lamps

Incandescent lamp E14 / E27	approx. 1,000 hrs
Halogen low voltage (no name)	500 - 2,000 hrs
Halogen low voltage (name-brand product)	2,000 - 4,000 hrs
T5 (Ø16mm) fluorescent lamp (6-13W)	approx. 7,000 hrs
T2 (Ø 7mm) fluorescent lamp	approx. 8,000 hrs
T8 (Ø26mm) fluorescent lamp (magnetic ballast)	approx. 13,000 hrs
Energy-saving lamp	4,000 - 19,000 hrs
T8 (Ø26mm) fluorescent lamp (electronic ballast)	approx. 20,000 hrs
T5 (Ø16mm) fluorescent lamp (14-80W)	approx. 24,000 hrs
LED (depending on style, control, cooling...)	10,000 - 100,000 hrs & up

The cooler the surroundings  
the more efficient the LED.



## Temperatures

### On-Chip

The life of LEDs is considerably reduced when exposed to high currents and temperatures on the chip. Without a heat sink the chip temperature would increase up to 200° C and the LED would malfunction within just a few minutes.

On-chip temperatures	
ARF, EH24, Flex	approx. 80° C
Eye	approx. 70° C
Stick/Twin-Stick	approx. 60° C
FlatLight	approx. 40° C

### In the beam

LEDs develop no heat in the beam, and are therefore ideal for heat-sensitive items, such as food.

Temperature comparison of illuminated surfaces

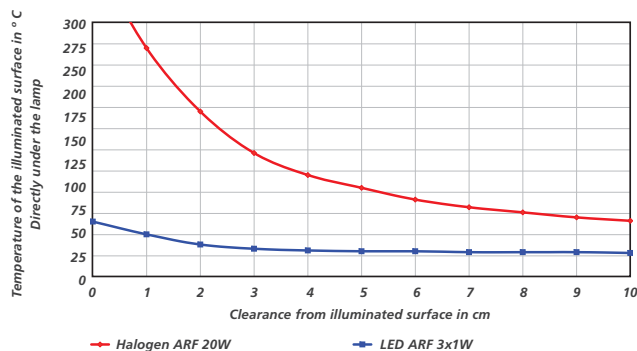

### Surrounding temperature

In contrast to the fluorescent lamp, the luminous intensity of the LED increases when the surrounding temperature is cool.

Comparison of luminous intensity relative to surrounding temperature

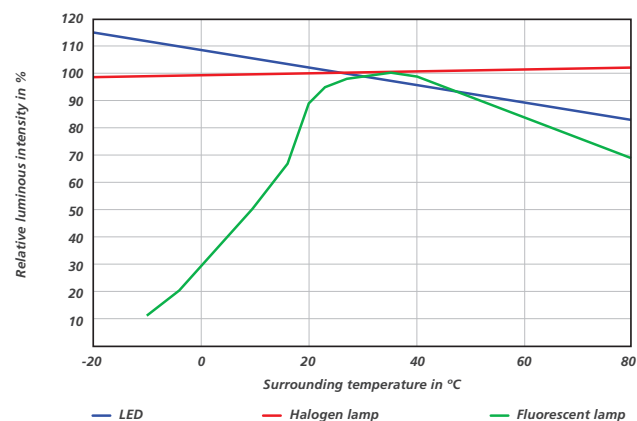

# What is light anyway?

Light can be defined as electromagnetic waves. Our conception of both light and colour refers to electromagnetic waves of a frequency that is visible to the human eye. Waves of other frequencies have no colour. Most are described by names which identify what they are used for.

The entire frequency range of electromagnetic waves is called the electromagnetic spectrum. This spans seamlessly from the lowest energy, long waves, e.g. radio waves, to the energy-rich, ultra-hard X-rays and gamma rays that come from a radioactive source. The visible light region occupies a

very narrow portion of the electromagnetic spectrum. It corresponds to the wavelengths 400 nm (violet) to 750 nm (red).

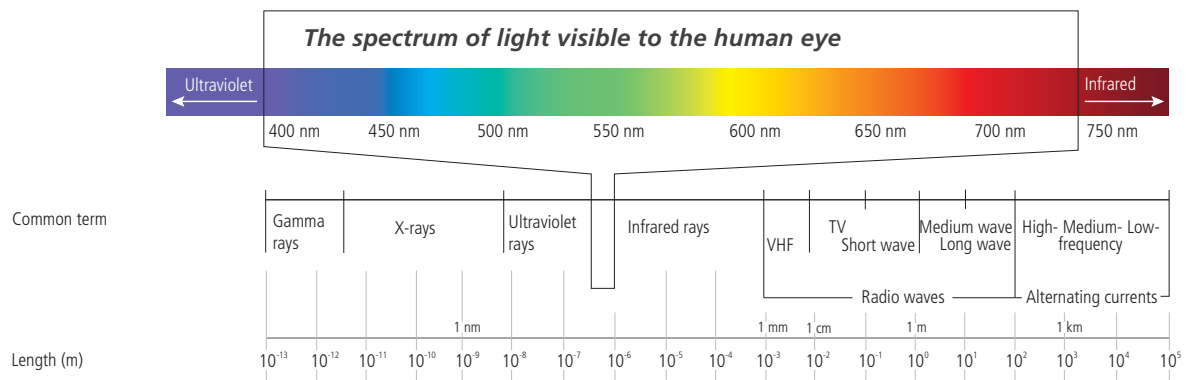

# Luminous colour/Colour temperature

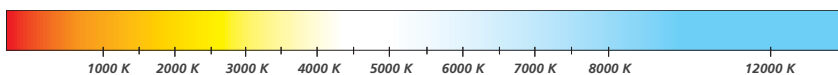

Light source	Colour temperature
Candle	1,500 K
Incandescent lamp (40W)	2,680 K
Incandescent lamp (100W)	2,800 K
Halogen lamp	3,000 K
Fluorescent tube (warm white)	3,000 K
Fluorescent tube (cool white)	4,000 K
Xenon/arc lamp	4,500 - 5,000 K
Midday sun	5,500 - 5,800 K
Fluorescent tube (daylight)	5,600 - 7,000 K
Overcast sky	6,500 - 7,500 K
Blue sky	8,000 - 12,000 K

The colour of light is defined in Kelvin (K). The lower the Kelvin, the "warmer" the light – from yellow to orange to red. The higher the Kelvin, the "cooler" (bluish-looking) the light.

The colour temperature of a light source is the temperature at which a material, e.g. a lamp filament or a fire's glow, arouses the same colour impression as the actual light source.

$$1^{\circ}\text{C} = 274 \text{ K}$$

$$2700^{\circ}\text{C} = 2,973 \text{ K}$$

# Binnings: Different „white shades“ of LEDs

White high-performance LEDs are subject to production tolerances as a result of tiny parameter fluctuations. To ensure uniformity, the LEDs are classified according to their colour and level of efficiency. Accordingly, those with similar values are binned together.

The closer the tolerances, the higher the quality of systems consisting of more than one LED.

It is not yet possible to manufacture a specific colour temperature with a small tolerance.

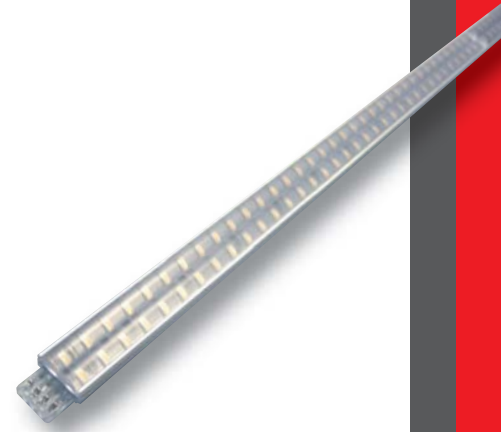

**Chromaticity diagram**

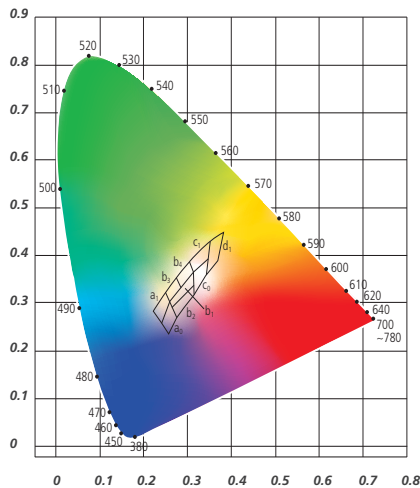

**Example: Binnings of white LEDs**

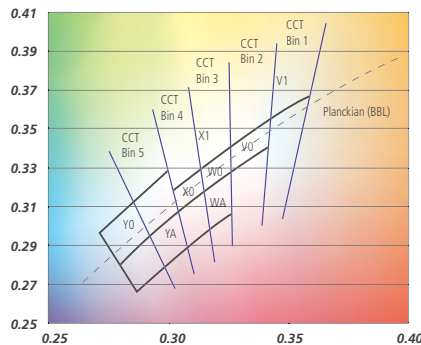

A binning contains LEDs which are virtually colour-matched.

## Colour temperatures of different LED luminaires by Hera

Product	Type	Colour temperature
ARF, EH 24, Eye, Flexlight, Point, ON TOP, Futura Plus	warm white	3.050 - 3.200 K
		3.200 - 3.450 K
	cool white	4.750 - 5.000 K
		5.000 - 5300 K
Stick, KB-12, Floor, EQ, ER, Q68, R68, DK 3, Vario	warm white	3.100 - 3.500 K
		3.250 - 3.600 K
	cool white	5.150 - 5.650 K
		5.200 - 5.650 K

# Colour rendering (Ra)

Colour rendering is an important quality feature of light.

A light source that contains the full spectrum of colours, e.g. sunlight, makes the colours of the illuminated items appear natural. Depending on use, artificial light should show objects in a light as natural as possible (as in normal daylight). The colour rendering properties of a light source,

expressed in levels according to the "general colour rendering index" Ra, are the benchmark for this. A light source with Ra = 100 reproduces all colours perfectly. The lower the Ra value, the less natural the colours reproduced.

## Colour rendering of different lamps expressed in Ra



## Colour rendering levels (Ra) of different lamps

Lamp	Colour rendering index
Halogen lamp	100
T5 fluorescent lamp	80 - 98
Compact fluorescent lamp	80 - 90
LED lamps ww (warm white)	80 - 90
LED lamps cw (cool white)	70 - 80
T8 fluorescent lamps	50 – 60, occasionally 80
High pressure mercury vapour lamps (e.g. street lighting)	40 - 59
High pressure sodium vapour lamps (e.g. street lighting)	20 - 89
Low pressure sodium vapour lamps (e.g. tunnel lighting)	<20

## Spectral radiance distribution of light sources

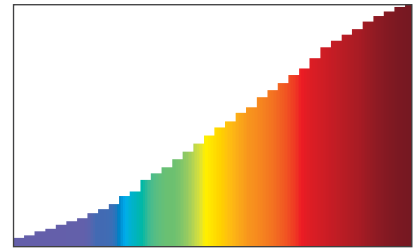

Halogen, Ra = 100

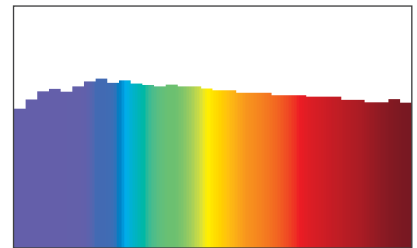

Sunlight, Ra = 100

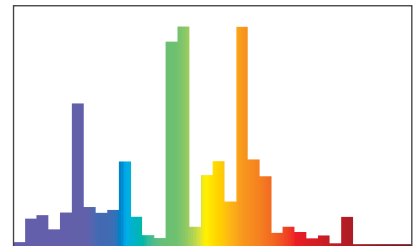

Fluorescent T5 cw, Ra = 80-89

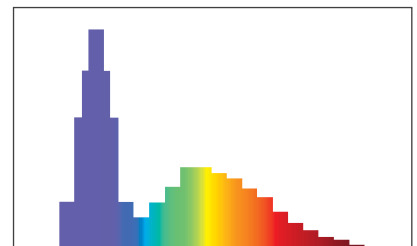

LED cw, Ra = 70

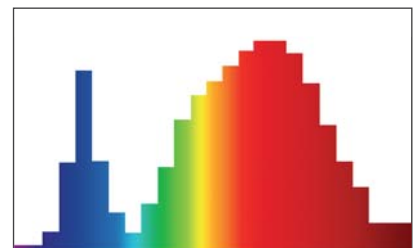

LED ww, Ra = 90



*/// The more balanced the red,  
green and blue spectral components  
of a light source, the better  
the colour rendition. ///*

Depending on use, a lamp should be selected on the basis of its colour rendition. Absolute colour fidelity is extremely important in the graphics industry, where lamps with a colour rendering index of much more than 90 must be used. To ensure that lighting is good and relaxing to work

in, lamps with a colour rendering index (CRI) of less than 80 should not be used in offices and workshops. In living rooms and bedrooms, where the light colour is less important, lamps can be selected according to the mood required rather than their colour rendering.

In commercial environments, colour rendition is often deliberately changed – to make meat appear an appetizing red, for instance. Poor colour rendering, however, can also unintentionally lead to some products (such as textiles) looking different in the shop than in daylight.

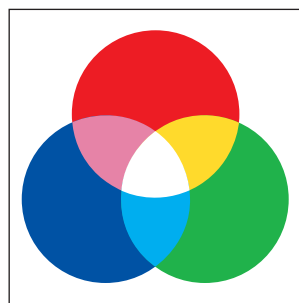

Nearly all white LEDs are in fact blue-emitting diodes combined with a luminescent colourant such as yellow-emitting phosphor. This process is used for about 99% of all LEDs for lighting purposes. It is relatively simple and produces a colour rendition of 70 – 90 Ra (depending on colour appearance).

To manufacture LEDs for specific purposes such as the health industry, a process called RGB colour mixing is used. Three LED chips of different colours (red, green, blue) are combined in a single housing to also

produce a white light. The term used here is „additive colour mixing“. It is a more complicated method, but the colour rendition is also better, at about Ra 95.

# Advantages of LEDs

## Advantages of LEDs

- high efficiency = low energy consumption
- minimal heat generation
- very long life expectancy (no maintenance costs)
- small size/design flexibility
- resistance to shocks and vibrations
- low voltage (SELV safety extra low voltage)
- no UV emissions/no "bleaching" of illuminated objects
- no IR radiation/no heating of illuminated objects
- no flickering

## Disadvantages of LEDs

- relatively high unit cost
- LEDs must be colour-selected for certain applications (see Binning)
- colour rendering properties of cool white LEDs are insufficient for some applications

# LED applications

- **UV-free beam**  
museum and display cabinet lighting  
illuminating paintings  
illuminating refrigerated counters  
lighting for medical purposes
- **Resistance to shock/vibrations**  
motor vehicles  
bicycle lamps  
task-lighting  
trucks  
motor homes  
boats
- **Miniaturized – low heat**  
furniture lighting  
orientation lighting  
displays
- **LED colour mixing**  
mood lighting  
gastronomy  
wellness
- **Long life**  
emergency and indication lighting  
signal lighting

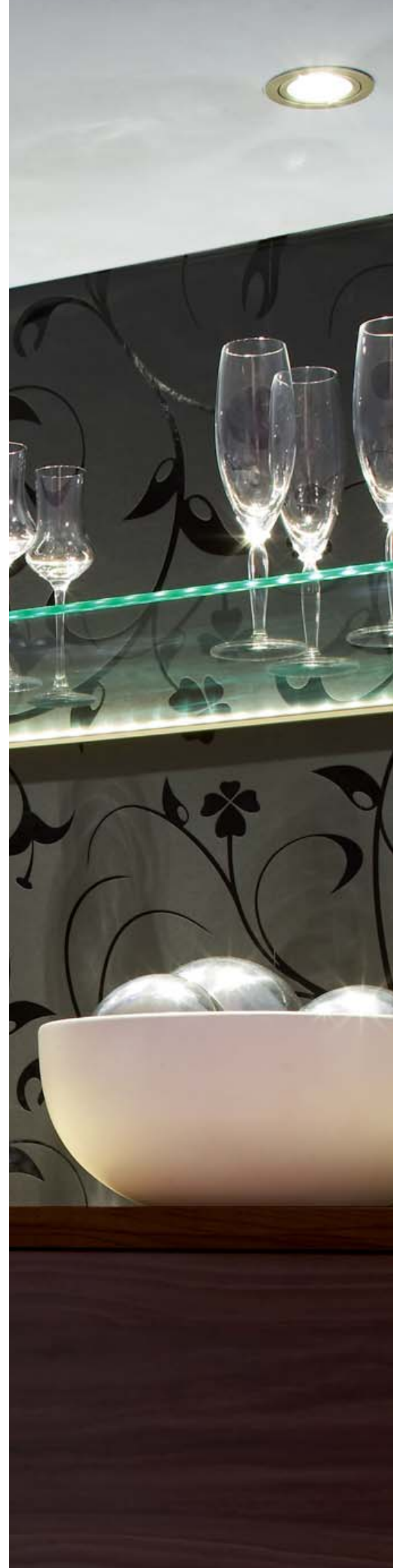

Special luminaires  
needs special transformers!

## Operation of LEDs/Transformers



### LED - Luminaires cannot be connected to standard halogen transformers.

As a rule, all types of LED are designed to run on a constant current:

Chip/SMD LED	10 ... 30 mA
3mm/5mm LED	10 ... 50 mA
Power LED	350 ... 1500 mA

This can be implemented in two different ways – by connection in parallel or in series.

### Parallel connection

#### Constant voltage transformer: 12VDC/24VDC for LED

- Parallel connection of the luminaires as for halogen luminaires
- The control and/or series resistors are situated inside the luminaire

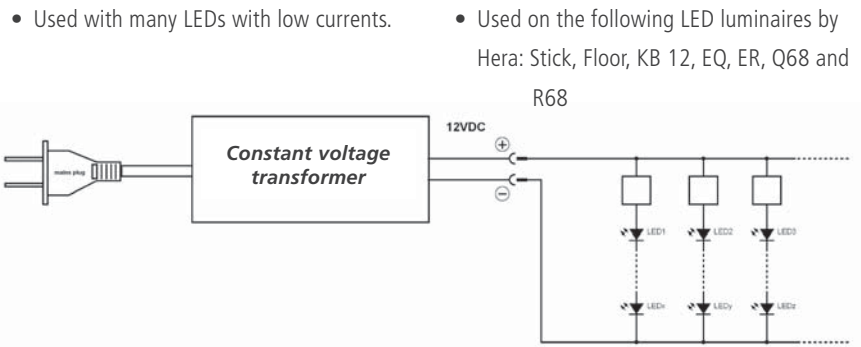

- Used with many LEDs with low currents.
- Used on the following LED luminaires by Hera: Stick, Floor, KB 12, EQ, ER, Q68 and R68

### Series connection

#### Constant current transformer: 350mA

- Series connection of the luminaires (unused sockets must be provided with short circuit plugs)
- The control and/or series resistors cannot

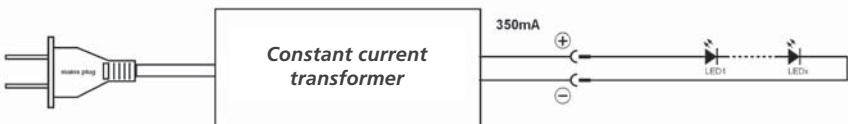

- be accommodated in the luminaire, because the high current would make cooling necessary (space problem)
- Used on single power LEDs with high operating currents
- Used on the following LED luminaires by Hera: ARF, EH 24, Eye, FlexLight, Point, ON TOP

## Dimming LEDs

Some transformers can be dimmed. However, this is not as easy as with halogen transformers by means of a phase-based and phase-shift dimmer. The dimmable LED transformers have two extra control cables for a 1-10V input. The easiest method is to connect a line -

transformer (Poti) which can adjust the brilliance only. An on/off switch for the prime conductor is also required. The more convenient solution is connection to a special concealed 1-10V dimmer, although this method requires the control cables and 230V cables to be re-laid.

The dimmer switch-/driver combination comes ready to use and the manual remote control in stainless steel finish can be easily stored using the mounting bracket provided.



***Hera***<sup>®</sup>

**Hera GmbH & Co. KG**  
Dieselstraße 9 · D-32130 Enger  
Postfach 440 · D-32124 Enger  
Telefon: +49 (0) 5224 911-0  
Telefax: +49 (0) 5224 911-215  
mail@hera-online.de  
www.hera-online.de

Subject to technical changes without prior notice.  
Status 03/2010