

# LED Twin-Stick 2

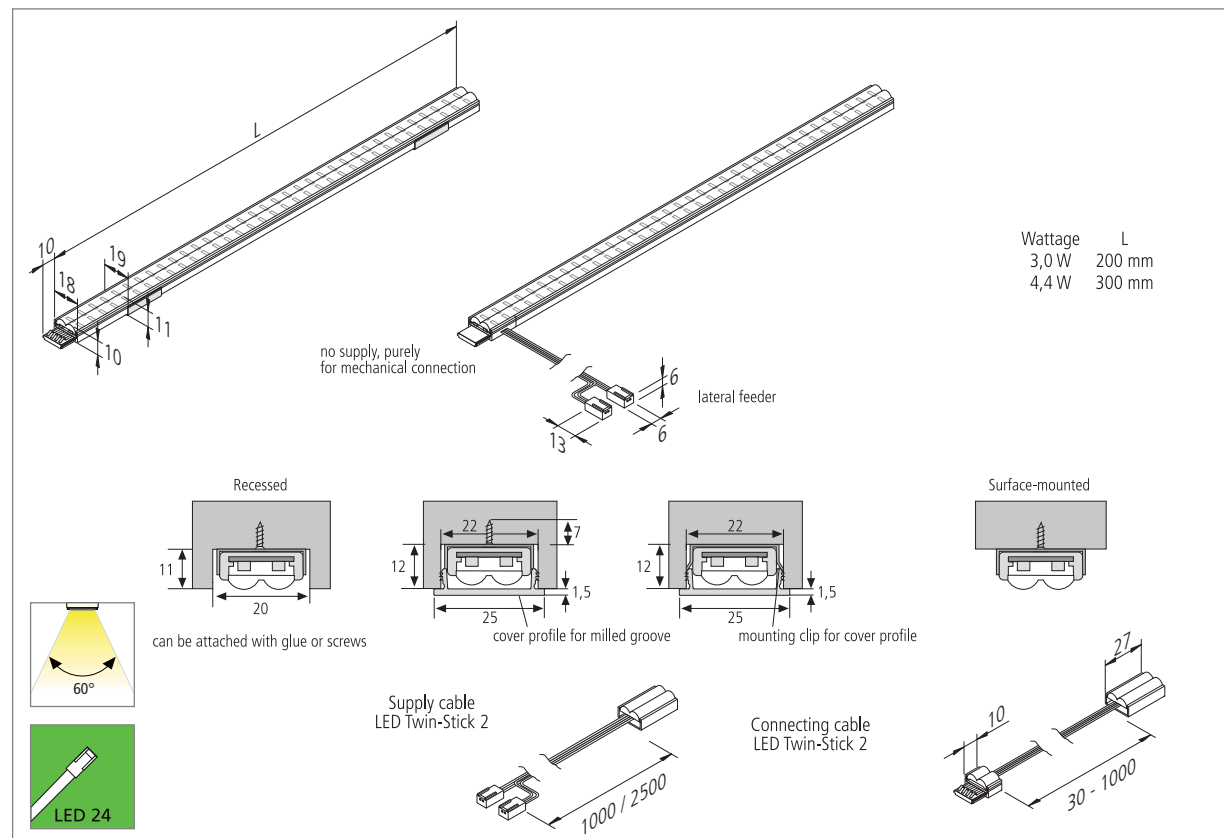

## Small, twin plug-in LED stick without dark zones

- Application:** surface-mounted luminaire for furniture and showcases containing heat-sensitive products
- Connection:** LED-transformer DC 24V
- Lamp:** extremely long-life 70 mW LED,  $\phi$  life 30,000 hours
- Energy efficiency:** good, ww + nw: 55lm/W; cw: 65lm/W
- Colour rendering:** good, ww + nw: Ra = 90; cw: Ra = 85
- Special features:** no UV rays; maximum 36W or 2,4m per supply cable; without dark zones; LED Stick with side-connection for continues strip lighting



# LED Twin-Stick 2

LED  
Fluorescent

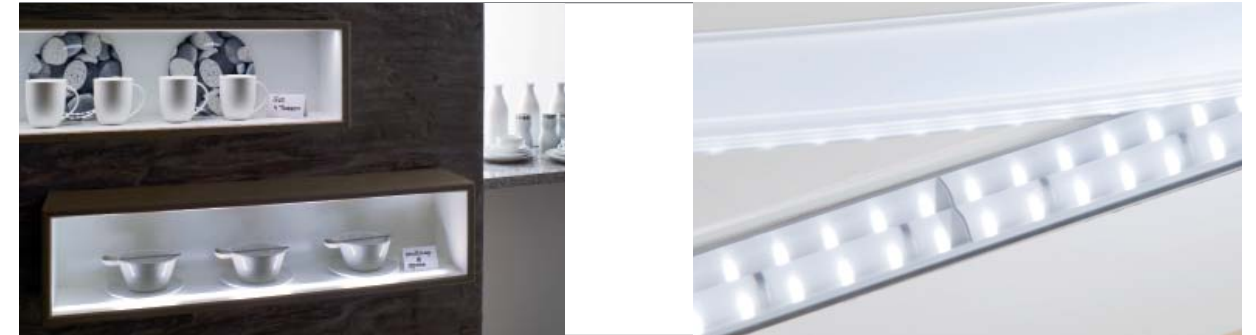

LED Twin-Stick 2 – the latest LED technology for general diffused lighting. Surface-mounted on furniture, displays, show-cases and cupboards. Illuminates without heating, ideal for delicate products. Available in various lengths, each in „cool white“, „neutral white“ and „warm white“.

NEW

NEW

NEW

NEW

NEW

Article No.	Description	Illustration	Features	Approx. weight
202 021 232 01	LED Twin-Stick 2 200mm 48 LED 3,0W cw		• colour appearance cw ( <b>cool white</b> ) approx. 5400K	45 g
202 021 233 01	LED Twin-Stick 2 300mm 72 LED 4,4W cw		• incl. lateral feeder 2,5m	68 g
202 021 233 11	LED Twin-Stick 2 300mm 72 LED 4,4W cw SE 2,5m		• colour appearance nw ( <b>neutral white</b> ) approx. 4000K	45 g
202 021 232 05	LED Twin-Stick 2 200mm 48 LED 3,0W nw		• incl. lateral feeder 2,5m	68 g
202 021 233 05	LED Twin-Stick 2 300mm 72 LED 4,4W nw		• colour appearance ww ( <b>warm white</b> ) approx. 3300K	45 g
202 021 233 15	LED Twin-Stick 2 300mm 72 LED 4,4W nw SE 2,5m		• incl. lateral feeder 2,5m	68 g
202 021 232 02	LED Twin-Stick 2 200mm 48 LED 3,0W ww		• connection between transformer and first Stick	45 g
202 021 233 02	LED Twin-Stick 2 300mm 72 LED 4,4W ww		• connection between two Twin-Sticks	68 g
202 021 233 12	LED Twin-Stick 2 300mm 72 LED 4,4W ww SE 2,5m		• included with Stick	110 g
215 270 625 32	Supply cable LED Twin-Stick 2 1000mm		• incl. 2 crews and 2 adhesive strips	21 g
215 272 625 02	Supply cable LED Twin-Stick 2 2500mm		• to cover the milled groove	40 g
215 270 600 22	Connecting cable LED Twin-Stick 2 30 mm		• material PC slightly matt	5 g
215 270 603 02	Connecting cable LED Twin-Stick 2 300 mm		• stainless steel	11 g
215 270 607 02	Connecting cable LED Twin-Stick 2 700 mm		• set of 2 for groove with cover profile	17 g
215 270 610 12	Connecting cable LED Twin-Stick 2 1000 mm		• mains cable 2m or 1,8m (60W) with Euro plug	21 g
202 040 107 04	Mounting clip LED Twin-Stick 2		• with 12-way distributor	4 g
203 012 801 10	Cover profile LED Stick 1000mm		• further information from page 127	47 g
203 012 801 54	Cover profile LED Stick 5400mm roll		• with radio telecontrol to dimm and to switch	255 g
213 041 080 08	Front cover for cover profile LED Stick		• further dimmable transformers from page 127	2 g
202 040 107 14	Mounting clip LED Twin-Stick 2 for cover profile			2 g
206 040 011 01	Transformer LED 24/15W DC 24V			167 g
206 040 012 01	Transformer LED 24/30W DC 24V			250 g
615 003 006 02	Transformer LED 24/60W DC 24V			355 g
615 003 007 09	Transformer LED 24/15W DC 24V dimmable (Radio Controller)			240 g
615 003 008 06	Transformer LED 24/30W DC 24V dimmable (Radio Controller)			325 g