

# SlimLite® CS

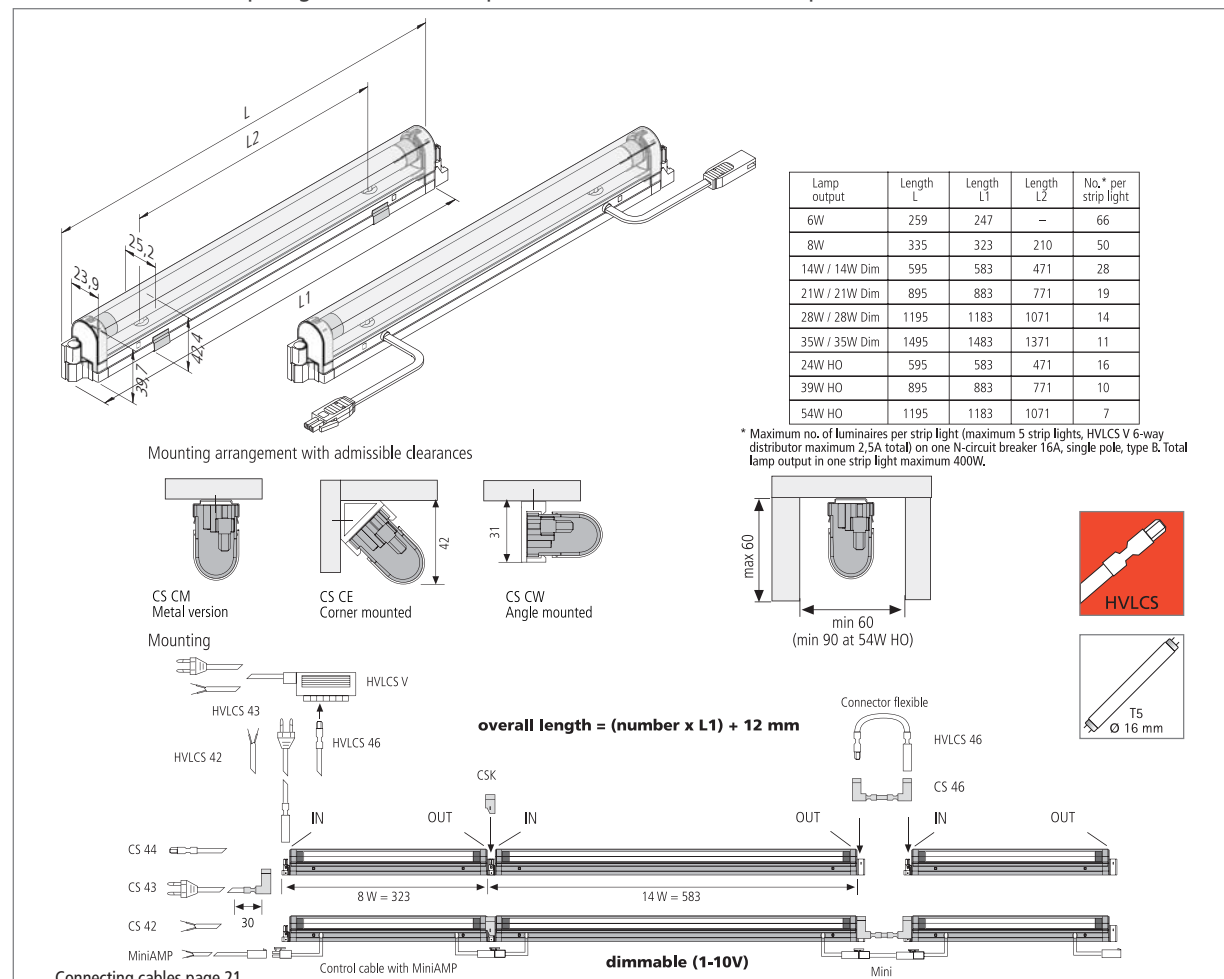

**HE - high efficiency** Fluorescent luminaire with a high light output, designed to be efficient and economical  
**HO - high output** Fluorescent luminaire with over 50% greater luminous flux output per lamp  
**DIM 1-10V** Dimmable luminaire with 1-10V control cables (Mini AMP plug and coupler; dimming area 10-100%); the luminaires cannot be operated with a leading or trailing edge dimmer. They can either be operated with the dimmer shown on page 138 or a 1-10V flush-mounted dimmer, requiring a 1-10V mini amp control cable and luminaire input lead to be connected to the dimmer.



# SlimLite® CS

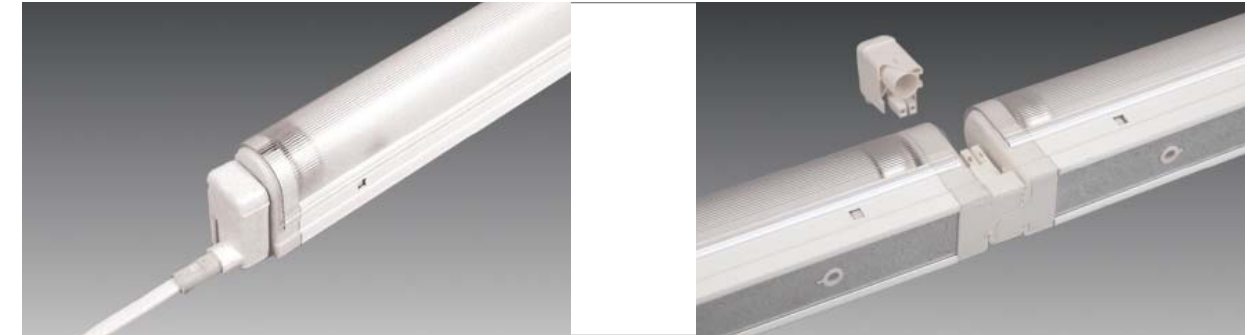

## Compact luminaire with aluminium casing and 8mm plug-in system

**Connection:** 220 – 240V / 50 – 60Hz  
**Lamp:** extremely long-life T5 (ø 16mm) high efficiency fluorescent lamp, ø life 20,000 hours or high output fluorescent lamp, ø life 24,000 hours  
**Energy efficiency:** very good, 86 – 94lm/W (14 – 35W)  
**Colour rendering:** good, Ra = 80 – 89  
**Special features:** flicker-free instant start and power-saving due to electronic ballast; ideal for food industry applications due to plexiglass cover (splinter shield); rigid connector for minimal spacing between luminaires; vertical plug-in system allows later removal from the strip light; many accessories; dimmable version 1-10V; from 8 W version „screw-through“.

Article No.	Description	Illustration	Features	Approx. weight		
501 150 100 00	SlimLite CS 259mm 6W		<ul style="list-style-type: none"> <li>• please order T5 lamps (from page 142) separately</li> <li>• plexiglass cover see below</li> <li>• from 8W „screw-through“</li> <li>• aluminium casing</li> <li>• incl. mounting clip CS CM</li> </ul>	120 g		
501 150 200 00	SlimLite CS 335mm 8W			150 g		
501 150 300 00	SlimLite CS 595mm 14W HE			260 g		
501 150 400 00	SlimLite CS 895mm 21W HE			360 g		
501 150 500 00	SlimLite CS 1195mm 28W HE			475 g		
501 150 600 00	SlimLite CS 1495mm 35W HE			565 g		
501 151 300 00	SlimLite CS 595mm 24W HO			260 g		
501 151 400 00	SlimLite CS 895mm 39W HO			360 g		
501 151 500 00	SlimLite CS 1195mm 54W HO			475 g		
501 152 030 00	SlimLite CS 595mm 14W dimmable (1-10V)				<ul style="list-style-type: none"> <li>• please order T5 HE lamps (from page 142) separately</li> <li>• plexiglass cover see below</li> <li>• „screw-through“</li> <li>• aluminium casing, incl. mounting clip CS CM</li> <li>• Dim range 10-100%</li> <li>• Dimmer page 138</li> </ul>	340 g
501 152 040 00	SlimLite CS 895mm 21W dimmable (1-10V)	440 g				
501 152 050 00	SlimLite CS 1195mm 28W dimmable (1-10V)	555 g				
501 152 060 00	SlimLite CS 1495mm 35W dimmable (1-10V)	645 g				
215 032 205 01	Mini AMP 1-10V mains cable 1m		<ul style="list-style-type: none"> <li>• with ferrules</li> <li>• for dimmable version 1 - 10V</li> </ul>			35 g
215 032 202 60	Mini AMP 1-10V connecting cable 0,15m					10 g
215 032 202 70	Mini AMP 1-10V connecting cable 0,3m			15 g		
215 032 202 80	Mini AMP 1-10V connecting cable 0,6m			25 g		
215 032 202 90	Mini AMP 1-10V connecting cable 1,2m			45 g		
215 032 202 02	Mini AMP 1-10V connecting cable 1,8m	65 g				
203 011 802 01	CS-PL plexiglass cover 6W		<ul style="list-style-type: none"> <li>• for HE, HO and dimmable version</li> </ul>	20 g		
203 011 802 02	CS-PL plexiglass cover 8W			30 g		
203 011 802 03	CS-PL plexiglass cover 14/24W			55 g		
203 011 802 04	CS-PL plexiglass cover 21/39W			80 g		
203 011 802 05	CS-PL plexiglass cover 28/54W			110 g		
203 011 802 06	CS-PL plexiglass cover 35W			130 g		
202 040 103 41	CS CM mounting clip metal version		<ul style="list-style-type: none"> <li>• 2 clips and 2 screws</li> <li>• 3 clips and 6 screws</li> </ul>	20 g		
202 040 103 42	CS CE mounting clip corner mounting 45°			20 g		
202 040 103 43	CS CW mounting clip angle mounting 90°			20 g		
Accessories	Connecting cables page 21					