

SlimLite® CS – The intelligent solution for variable strip lighting



Hera®
Light Years Ahead.

About Hera



Hera headquarters in Enger



Hera headquarters in Norcross, USA

Hera - your global partner

Tradition, partnership and innovation are inextricably linked at Hera. Since the company was launched we have constantly implemented new ideas and forward-looking solutions. At the same time we have worked closely with our customers to develop new technologies. And to ensure that this does not change, we consistently invest in research and development.

You can benefit worldwide from our creativity and expertise in conceptual design, development, construction, assembly, tool-making, installation and service. Hera offers you products from a one-stop source – innovative, on schedule and geared to success.

*Our work -
your success!*

Our services for you:

- Market-driven standard range – individual tailor-made solutions
- Staff who understand you
- Always at the cutting edge of technology
- Punctual delivery
- Minimal tools required = cost savings on mounting
- Best quality at attractive prices



Our employees are always receptive to the wishes of our customers



Tried and tested quality

SlimLite® CS – five options, one system

The SlimLite® CS is an intelligent linear luminaire system that makes it so easy to create a memorable ambiance.

The apparent „simplicity“ of the luminaire conceals a range of practical accessories to make its installation both flexible and versatile.

HE - high efficiency

Fluorescent luminaire with a high light output, designed to be efficient and economical

HO - high output

Fluorescent luminaire with over 50% greater luminous flux output per lamp

DIM 1-10V

Dimmable luminaire with 1-10V control cables (mini AMP plug and coupler; dimming area 10-100%)

Reflector

Ensures maximum light output and high energy efficiency. (For use as an accessory with HE, HO and DIM)

Seamless

Offering long strip lights, without any dark spots



SlimLite® CS Reflector

Easy installation



1. Mounting the clips



2. Fitting the reflector



3. Fitting the lamp

More light – less energy

SlimLite® CS Reflector is the ideal lighting solution for bright and economic illumination for all kind of products. The aluminium reflector's exceptional light bundle characteristics and a 50° light beam transform the SlimLite® CS into a powerful lighting system with extraordinary energy saving potential.

as the other SlimLite® CS lamps. In addition to the standard installation, for an asymmetrical lighting it is also possible to fix this luminaire at a 25° angle. A dimmable version is also available wherever mood lighting suits your room concept.

It is also just as simple and easy to install

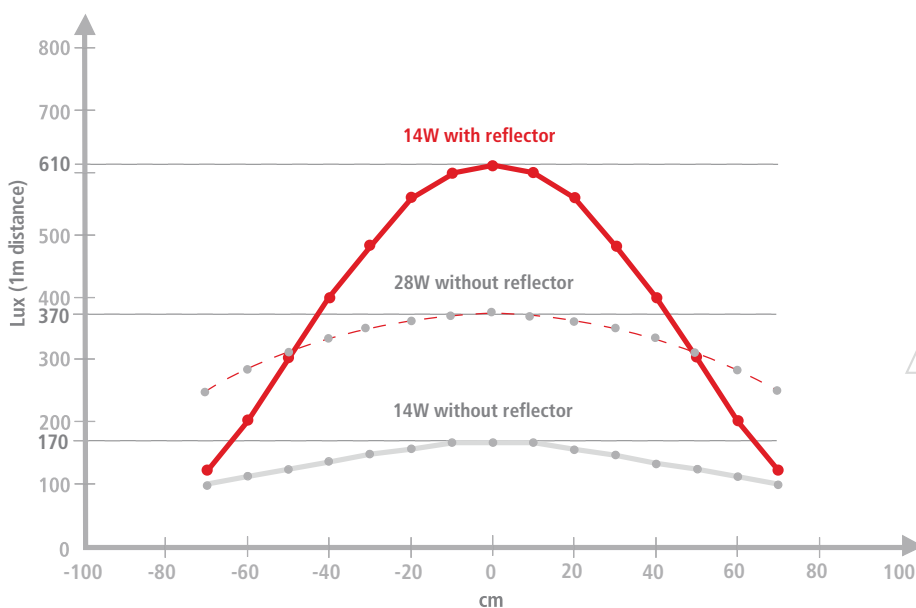

0°



25°



Advanced lighting technology with optimal energy efficiency



4. Attaching the end caps



5. Connecting the luminaire



SlimLite® CS Seamless

Long strip lights
without dark spots

Continuous lighting

The SlimLite® CS Seamless is the ideal lighting system for creating long, seamless light-bands, with virtually no dark spots. This model can be adapted to any room layout, is available in three different lengths and therefore offers an endless range of design possibilities. Depending on the output of each lamp, a total of 7 to 15 lamps can be linked up.

Another advantage of this system is that it can be screwed in, making the installation easy as child's play without the use of additional clips. The average lifetime of the fluorescent lamp is 12.000 hours.



One connecting system for all versions



Vertical luminaire connection



Horizontal luminaire connection



6-way distributor with option to connect a switch

Heaps of power supply options

The SlimLite® CS can be connected to 220–240 V/50–60 Hz, depending on whether used with a vertical or horizontal luminaire connection that is provided either with a Euro plug or only with ferrules. With a 6-way distributor you have the option of linking up 6 luminaires or strip lights and controlling them with a combined switch.

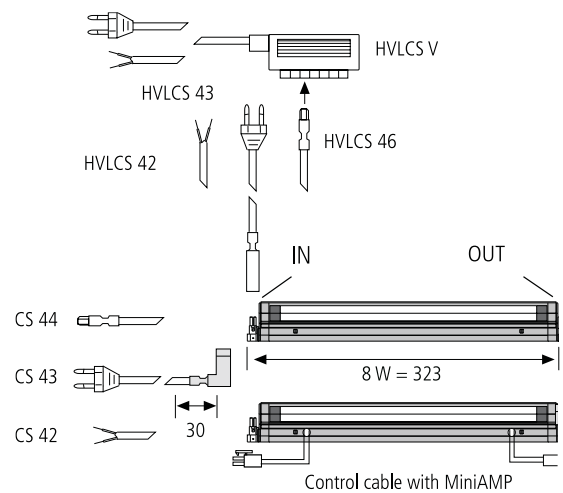

A connector so small,
it fits through an 8 mm hole.

¹⁾ SlimLite® CS Seamless – horizontal connection only

Simple to connect



The SlimLite® CS-System is the ideal lighting solution to create very long strip lighting systems with virtually no dark zones.

The luminaires are available in 6 different lengths (see table p. 9). Tiny smart connectors and a wide range of connecting cables offering comprehensive wiring

capabilities. The extremely long-life T5 (ø 16 mm) high efficiency fluorescent lamp with an average life of 24,000 hours makes the SlimLite® CS an exceptionally energy-efficient luminaire.

1. The offset positioning of the contacts minimises the dark zones between the luminaires. Nonetheless, being plugged in from the front, individual luminaires can be replaced quite easily.



Flexible installation with and without luminaire spacing

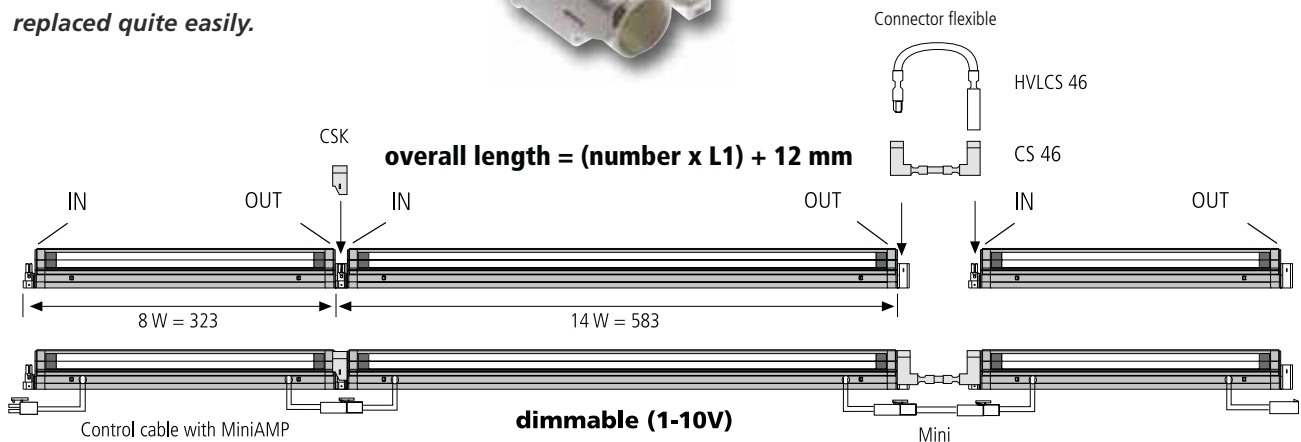

2. Fitting the connector



3. Contacts maintained perfectly using a mechanical lock system



Flexible plug and socket connector

Branching out made easy

Once all the cables have been laid nothing could be simpler than to add another luminaire, or even an entire strip of luminaires. Exactly where you want it. Just snap a T-adaptor with socket wherever you like onto the cable, insert plug and socket – done. A crimping tool is needed, which is available on request. Insert another Y-distributor and one extra branch becomes two. Depending on lamp output, a total of up to 50 luminaires can be linked up (See table p. 9).



Snapping on the T-Adaptor



T-Adaptor with supply cable



Two-way distributor with male plug and two female sockets

Mini socket outlet

The flush-mounted sockets for wood or metal available in our accessories range are a neat solution when plugs and sockets are needed in furniture, shelving units or show-cases.

The socket for wood, together with a connecting cable, is simply pressed into a 13 mm hole in wood from 10 mm thickness.

The socket for metal is also inserted in a thickness 13 mm hole in metal of 0–18 mm thick and then screwed in from behind with an internal screw. Now simply insert another cable with an HVLCs plug and a power connection for max. 2.5 A is ready for use.



The wood version grips into the cavity, while the metal version is screwed in with an internal screw.



Flush-mounted socket for wood



Flush-mounted socket for metal



Flush-mounted socket with connecting cable becomes a mini socket outlet

Simple mounting – really fast



Easy installation with snap-in technology



From 8 W version "screw-through"

Its "screw-through" ability gives the SlimLite® CS a special installation advantage. The luminaire can be screwed on in one step, without any extra clips. If direct installation proves to be difficult in pre-mounted furniture because there is insufficient room for the necessary tools, clips can be mounted beforehand. The luminaire can then simply be pushed on (no need for tools), and can be removed again at any time.

Lamp output	Length L	Length L1	Length L2	No.* per strip light
6 Watt	259	247	–	50
8 Watt	335	323	210	40
14 W / 14W Dim	595	583	471	23
21 W / 21W Dim	895	883	771	16
28 W / 28W Dim	1195	1183	1071	12
35 W / 35W Dim	1495	1483	1371	9
24 Watt HO	595	583	471	15
39 Watt HO	895	883	771	9
54 Watt HO	1195	1183	1071	7
Seamless 24 Watt	580	481	381	15
Seamless 39 Watt	880	781	681	9
Seamless 54 Watt	1180	1081	981	7

*Maximum number of luminaires per strip light (maximum 6 strip lights) on one N-circuit breaker 16 A, single pole, type B

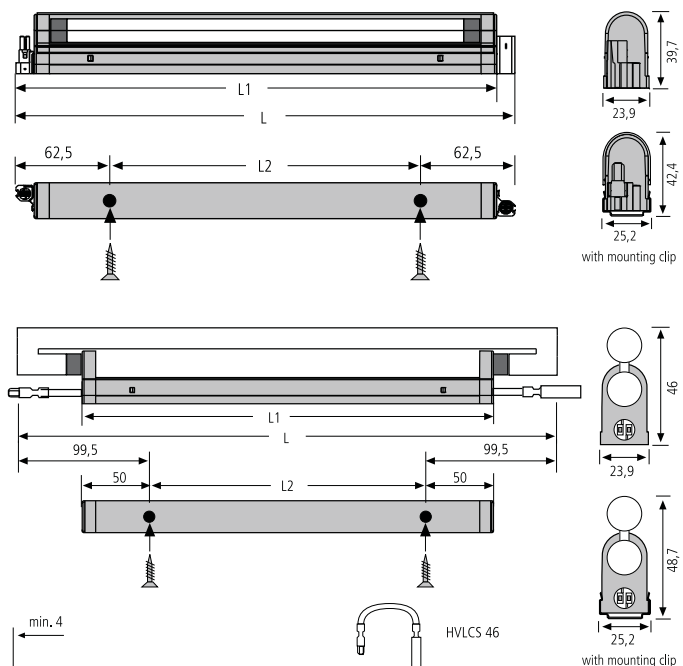

Simple installation option due to clip technology

Regardless of the type of mounting – at 45° in a corner or in a 90° angle – here too the correct mounting clips are available in our range of accessories.

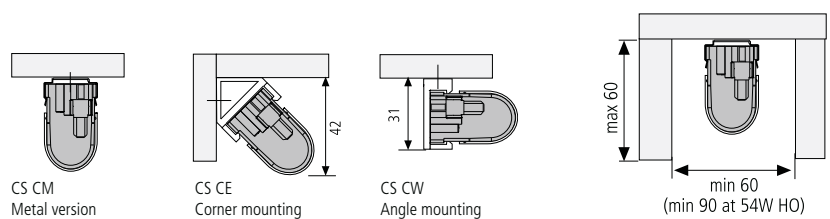
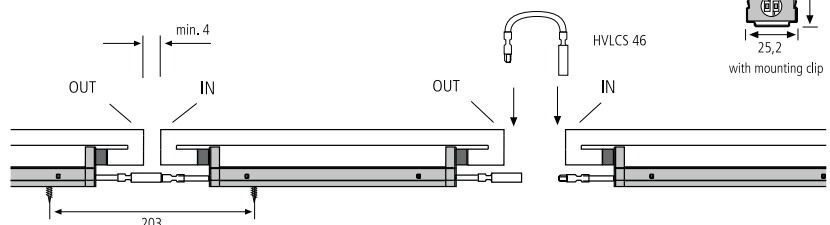

Order number index

Lighting

NEW
NEW
NEW

Article No.	Description	Illustration	Features	Approx. weight.
501 150 100 00	SlimLite CS 259mm 6W		<ul style="list-style-type: none"> • Please order T5 lamps separately • Plexiglass cover see below • 8-35 W "screw-through" • incl. mounting clip CS CM 	120 g
501 150 200 00	SlimLite CS 335mm 8W			150 g
501 150 300 00	SlimLite CS 595mm 14W HE			260 g
501 150 400 00	SlimLite CS 895mm 21W HE			360 g
501 150 500 00	SlimLite CS 1195mm 28W HE			475 g
501 150 600 00	SlimLite CS 1495mm 35W HE			565 g
501 151 300 00	SlimLite CS 595mm 24W HO		<ul style="list-style-type: none"> • please order T5 HO lamps separately • plexiglass cover see below • 24 – 54W „screw-through“ • aluminium casing, incl. CS CM 	260 g
501 151 400 00	SlimLite CS 895mm 39W HO			360 g
501 151 500 00	SlimLite CS 1195mm 54W HO			475 g
501 153 300 00	SlimLite CS Seamless 580 mm 24W HO		<ul style="list-style-type: none"> • please order T5 HE lamps separately • plexiglass cover see below • 14 – 35W „screw-through“ • aluminium casing • incl. mounting clip CS CM 	260 g
501 153 400 00	SlimLite CS Seamless 880 mm 39W HO			360 g
501 153 500 00	SlimLite CS Seamless 1180 mm 54W HO			475 g
501 152 030 00	SlimLite CS 595mm 14W dimnable (1-10V)		<ul style="list-style-type: none"> • please order T5 HE lamps separately • plexiglass cover see below • 14 – 35W „screw-through“ • aluminium casing • incl. mounting clip CS CM 	340 g
501 152 040 00	SlimLite CS 895mm 21W dimnable (1-10V)			440 g
501 152 050 00	SlimLite CS 1195mm 28W dimnable (1-10V)			555 g
501 152 060 00	SlimLite CS 1495mm 35W dimnable (1-10V)			645 g

Zubehör

Article No.	Description	Illustration	Features	Approx. weight.
215 260 218 01	CS 42/1800 mains cable with AE 1,8m		<ul style="list-style-type: none"> • horizontal luminaire connection with AE (ferrules), Euro (Euro plug), Schuko (Shockproof plug loose) or HVLCS plug 	70 g
215 260 230 01	CS 42/3000 mains cable with AE 3m			100 g
215 260 318 01	CS 43/1800 mains cable with Euro 1,8m			90 g
215 260 330 01	CS 43/3000 mains cable with Schuko 3m			130 g
215 260 418 01	CS 44/1800 mains cable with HVLCS 1,8m			70 g
215 260 601 01	CS 46/ 150 connecting cable 0,15m			15 g
215 260 603 01	CS 46/ 300 connecting cable 0,3m			20 g
215 260 606 01	CS 46/ 600 connecting cable 0,6m			30 g
215 260 612 01	CS 46/1200 connecting cable 1,2m			50 g
215 260 618 01	CS 46/1800 connecting cable 1,8m			70 g
215 260 000 01	CSK connecting coupling		4 g	
215 440 220 02	HVLCS 42/2000 mains cable with AE 2m		<ul style="list-style-type: none"> • vertical luminaire connection with AE (ferrules) or Euro (Euro plug) 	70 g
215 440 320 01	HVLCS 43/2000 mains cable with Euro 2m			90 g
215 441 120 01	HVLCS V/2000 6-way distributor with Euro 2m			120 g
215 440 601 01	HVLCS 46/ 150 connecting cable 0,15m			20 g
215 440 605 01	HVLCS 46/ 500 connecting cable 0,5m			30 g
215 440 610 01	HVLCS 46/1000 connecting cable 1m			45 g
215 440 615 01	HVLCS 46/1500 connecting cable 1,5m			60 g
215 440 620 01	HVLCS 46/2000 connecting cable 2m			75 g
215 441 300 01*	HVLCS Y-distributor		<ul style="list-style-type: none"> • with one plug and 2 sockets • can be snapped onto any part of the cable • for wood from 10 mm with 13 mm cavity • for metal from 0–18 mm with 13 mm cavity 	4 g
215 441 400 01*	HVLCS T-Adaptor with one socket			3 g
215 441 500 01	HVLCS H Wood flush-type socket			1 g
215 441 501 11	HVLCS B Metal flush-type socket (with internal screw)			4 g
203 011 802 01	CS-PL plexiglass cover 6W		<ul style="list-style-type: none"> • for HE, HO and dimmable version 	20 g
203 011 802 02	CS-PL plexiglass cover 8W			30 g
203 011 802 03	CS-PL plexiglass cover 14/24W			55 g
203 011 802 04	CS-PL plexiglass cover 21/39W			80 g
203 011 802 05	CS-PL plexiglass cover 28/54W			110 g
203 011 802 06	CS-PL plexiglass cover 35W			130 g

Accessories (cont.)

Article No.	Description	Illustration	Features	Approx. weight.
202 040 103 41	CS CM mounting clip metal version		• 2 clips and 2 screws	20 g
202 040 103 42	CS CE mounting clip corner mounting 45°		• 3 clips and 6 screws	20 g
202 040 103 43	CS CW mounting clip angle mounting 90°		20 g	
204 040 101 00	CS- Reflector 180mm 6W		• Mount clip (0° or 25°- see below).	15g
204 040 102 00	CS- Reflector 256mm 8W			20g
204 040 103 00	CS- Reflector 516mm 14/24W			40g
204 040 104 00	CS- Reflector 816mm 21/39W			65g
204 040 105 00	CS- Reflector 1116mm 28/54W			90g
204 040 106 00	CS- Reflector 1416mm 35W			115g
202 040 103 44	CS CR mount clip for 0° reflector			
202 040 103 45	CS CR mount clip for 25° reflector	20g		

NEW

Lamps

Article No.	Description	Dimensions	Luminous flux max.	Approx. weight
201 010 104 01	Fluorescent lamp T5 L 6W/630 Standard ww	L = 212mm T5 (ø 16mm)	270lm	20 g
201 010 109 07	Fluorescent lamp T5 L 6W/640 Standard cw		270lm	20 g
201 010 119 02	Fluorescent lamp T5 L 8W/827 Lumilux interna	L = 288mm T5 (ø 16mm)	450lm	30 g
201 010 106 00	Fluorescent lamp T5 L 8W/830 Lumilux ww		450lm	30 g
201 010 111 07	Fluorescent lamp T5 L 8W/840 Lumilux cw		430lm	30 g
201 010 401 01	Fluorescent lamp T5 HE 14W NATURE superb	L = 549mm T5 (ø 16mm) High Efficiency	900lm	50 g
201 010 119 11	Fluorescent lamp T5 HE 14W/827 Lumilux interna		1200lm	50 g
201 010 120 72	Fluorescent lamp T5 HE 14W/830 Lumilux ww		1200lm	50 g
201 010 120 01	Fluorescent lamp T5 HE 14W/840 Lumilux cw		1200lm	50 g
201 010 120 81	Fluorescent lamp T5 HE 14W/865 Lumilux dl		1100lm	50 g
201 010 401 02	Fluorescent lamp T5 HE 21W NATURE superb	L = 849mm T5 (ø 16mm) High Efficiency	1400lm	75 g
201 010 119 12	Fluorescent lamp T5 HE 21W/827 Lumilux interna		1900lm	75 g
201 010 120 41	Fluorescent lamp T5 HE 21W/830 Lumilux ww		1900lm	75 g
201 010 120 02	Fluorescent lamp T5 HE 21W/840 Lumilux cw		1900lm	75 g
201 010 120 82	Fluorescent lamp T5 HE 21W/865 Lumilux dl		1750lm	75 g
201 010 401 03	Fluorescent lamp T5 HE 28W NATURE superb	L = 1149mm T5 (ø 16mm) High Efficiency	1950lm	105 g
201 010 119 13	Fluorescent lamp T5 HE 28W/827 Lumilux interna		2600lm	105 g
201 010 120 51	Fluorescent lamp T5 HE 28W/830 Lumilux ww		2600lm	105 g
201 010 120 11	Fluorescent lamp T5 HE 28W/840 Lumilux cw		2600lm	105 g
201 010 120 83	Fluorescent lamp T5 HE 28W/865 Lumilux dl		2400lm	105 g
201 010 401 04	Fluorescent lamp T5 HE 35W NATURE superb	L = 1449mm T5 (ø 16mm) High Efficiency	2450lm	135 g
201 010 119 14	Fluorescent lamp T5 HE 35W/827 Lumilux interna		3300lm	135 g
201 010 120 21	Fluorescent lamp T5 HE 35W/830 Lumilux ww		3300lm	135 g
201 010 120 31	Fluorescent lamp T5 HE 35W/840 Lumilux cw		3300lm	135 g
201 010 120 84	Fluorescent lamp T5 HE 35W/865 Lumilux dl		3050lm	135 g
201 010 117 12	Fluorescent lamp T5 HO 24W/830 Lumilux ww	L = 549mm T5 (ø 16mm) High Output	1750lm	50 g
201 010 117 52	Fluorescent lamp T5 HO 24W/840 Lumilux cw		1750lm	50 g
201 010 117 11	Fluorescent lamp T5 HO 39W/830 Lumilux ww	L = 849mm	3100lm	75 g
201 010 117 53	Fluorescent lamp T5 HO 39W/840 Lumilux cw		3100lm	75 g
201 010 117 13	Fluorescent lamp T5 HO 54W/830 Lumilux ww	L = 1149mm	4450lm	105 g
201 010 117 51	Fluorescent lamp T5 HO 54W/840 Lumilux cw		4450lm	105 g
201 010 121 11	Fluorescent lamp T5 HO 24W/830 ww Seamless	L=580mm T5 (Seamless) High Output	1750lm	50 g
201 010 121 01	Fluorescent lamp T5 HO 24W/840 cw Seamless		1750lm	50 g
201 010 121 12	Fluorescent lamp T5 HO 39W/830 ww Seamless	L=880mm	3100lm	75 g
201 010 121 02	Fluorescent lamp T5 HO 39W/840 cw Seamless		3100lm	75 g
201 010 121 13	Fluorescent lamp T5 HO 54W/830 ww Seamless	L=1180mm	4450lm	105 g
201 010 121 03	Fluorescent lamp T5 HO 54W/840 cw Seamless		4450lm	105 g



Hera[®]

Hera GmbH & Co. KG
Dieselstraße 9 · D-32130 Enger · Germany
PO Box 440 · D-32124 Enger · Germany
Tel.: +49 (0) 5224 911-0
Fax: +49 (0) 5224 911-215
mail@hera-online.de
www.hera-online.de

Subject to alterations
Status 09/2009