

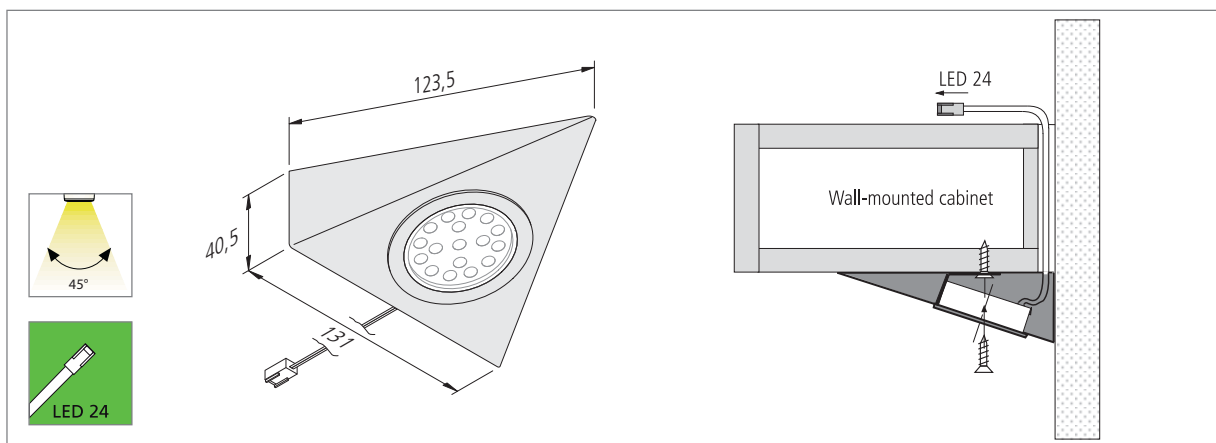

## Triangular LED Under-Cabinet Luminaire in Stainless Steel

- Application:** decorative LED lighting for kitchens
- Connection:** LED transformer DC 24V
- Lamp:** extremely long-life 24 x 67mW LED,  $\varnothing$  life 30,000 hours
- Energy efficiency:** good, 55lm/W
- Colour rendering:** good, Ra = 90
- Special features:** casing of brushed stainless steel; easy to assemble with only one screw; electronic contact switch EBS 4 as an optional extra.



Article No.	Description	Features	Approx. weight
610 008 401 08	UL 1-LED 1.6W ww stainless steel	• supply cable 2.5m with LED 24 plug	175 g
610 545 300 08	set of 3 UL 1-LED 1.6W ww stainless steel	• incl. transformer LED 24/15W	695 g
610 546 300 08	set of 3 UL 1-LED 1.6W ww with switch stainless steel	• incl. transformer LED 24/15W and EBS-4	845 g
215 300 610 01	LED 24 connecting cable 1m		9 g
215 300 625 01	LED 24 connecting cable 2.5m		22 g
206 040 011 01	Transformer LED 24/15W DC 24V 12-way distributor	• mains cable 2m with Euro plug	167 g
506 110 301 01	EBS-4 D with 1m Euro plug + 0.3m Euro coupling	• incl. sensor cable 2m (further information on page 135)	150 g