

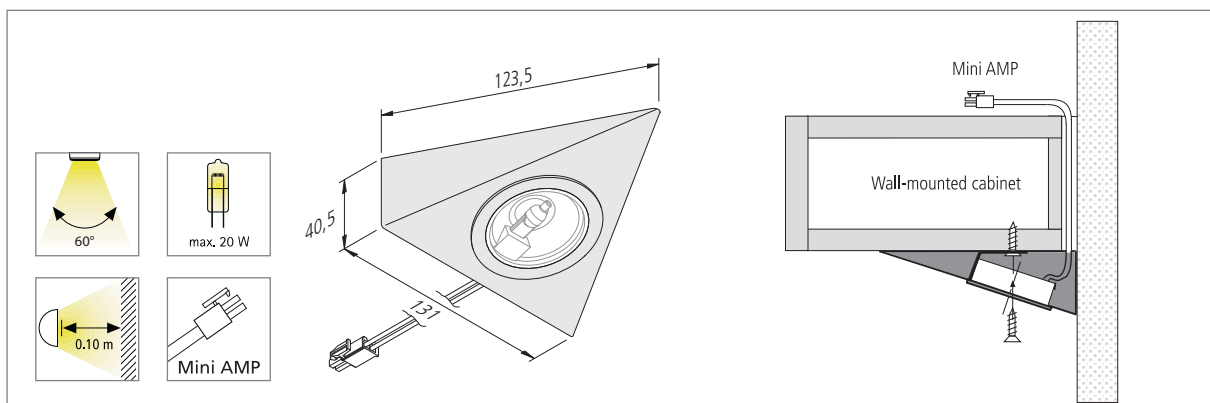

Triangular Halogen Under-Cabinet Luminaire in Stainless Steel

- Application:** decorative halogen lighting for kitchens, shops and exhibitions
Connection: halogen transformer 12V
Lamp: long-life G4 halogen lamp "OSRAM HALOSTAR STARLITE®",
 ø life 4,000 hours / max. 20W
Energy efficiency: satisfactory, 13 – 16lm/W (10 – 20W)
Colour rendering: very good, Ra = 100
Special features: casing of brushed stainless steel; easy to assemble with only one screw;
 electronic contact switch EBS 4 as an optional extra.



Article No.	Description	Features	Approx. weight
610 008 200 68	UL 1 20W stainless steel	• supply cable 1.8m with Mini AMP plug included loose	175 g
610 521 200 18	set of 2 UL 1 20W stainless steel	• incl. transformer Vega K70	550 g
610 521 300 18	set of 3 UL 1 20W stainless steel	• incl. transformer Vega K70	725 g
610 524 030 28	set of 3 UL 1 20W stainless steel with switch	• incl. transformer Puma 105 and EBS-4 D	890 g
610 521 500 18	set of 5 UL 1 20W stainless steel	• incl. transformer Puma 105	1085 g
215 032 202 20	Mini AMP connecting cable 0.5m	• further information on page 130	25 g
215 032 202 10	Mini AMP connecting cable 1m		40 g
215 032 202 02	Mini AMP connecting cable 1.8m		65 g
506 110 303 11	EBS-4 D with 1m Euro plug + 0.3m Euro coupling	• incl. sensor cable 2m (further information on page 135)	135 g
506 110 301 01	EBS-4 D with 1m Euro plug + 0.3m Euro coupling		150 g
Accessories:	Transformers for halogen luminaires from page 116		